

SPECIFICATION

MENTION INDEX

1. Applicable safety standard	1.
2. Acquired Safety Standards approval	1.
3. Part Number	1.
4. Marking	6.
5. Rating and Characteristics	7.
6. Specifications and Test Methods	8.
7. Characteristics Data	12.
8. Taping specification	13.
9. Packaging Styles	15.
10. Packaging Quantity	16.
11. Label and Transport	16.
12. Notification before the modification	16.

DIVISION	DATE ISSUED	SPEC.NO.
TECH. DERT	May. 3. 2012	WM-S08-009B07

HJ TYPE -FOR(Reinforced Insulation)-IEC60384-14-ClassX1,Y1

1. Applicable Safety Standard

This specification applies to the VDE-ENEC,UL,CQC,CSA,,KC,JET, approved ceramic capacitors dist type for antenna-coupling,line-by-pass and across-the-line.

2. Acquired Safety Standard Approval and Recognized number

Safety Standard	Standard No.	Recognition No.	Rated Voltage
VDE-ENEC	DIN EN60384-14(VDE 0565 Teil1-1):2006-04; EN60384-14:2005-08; IEC60384-14(ed.3)	40034438	X1:400V~ Y1:250V~
UL	UL60384-14	E221839	
CQC	GB/T14472-1998	CQC09001040207	
CSA	CSA-E60384-14:09	2386012	
KC	K60384-14	SU03040-8003/4A	
JET	J60384-14(JISC5101-14)	1417-C9901-022	

3. Part Numbers

Examples HJ E 222 M H 4 B 3.5 W
 ① ② ③ ④ ⑤ ⑥ ⑦ ⑧ ⑨

- ① Type
- ② Temperature Characteristics
- ③ Nominal Capacitance
- ④ Capacitance Tolerance Symbol
- ⑤ Lead Style
- ⑥ Lead Spacing
- ⑦ Packaging
- ⑧ Lead length
- ⑨ Internal code

3.1 Type

Type Designation

Code	Safety Standard Recognized Type
HJ	X1: AC400V,Y1:AC250V

3.2 Temperature Characteristics Code

Code	Temperature Characteristics	Cap.Change Of Temp.coeff.	Temperature Range
S	SL	+350~-1000ppm/°C	-25 to 85°C
B	Y5P	±10%	
E	Y5U	+20%~-55%	

3.3 Nominal Capacitance Code

Nominal capacitance shall consist of three numerals in the unit of picofarad(Pf). The first and second numerals mean the significant figures, and the third numeral shall represent the number of zeros following the significant figures.

Example:

Code	Capacitance(pF)
101	100
102	1000
222	2200
103	10000

3.4 Capacitance Tolerance

Code	Tolerance
K	±10%
M	±20%

3.5 Lead style

3.5.1: Straight long lead (Lead Style Code :A)

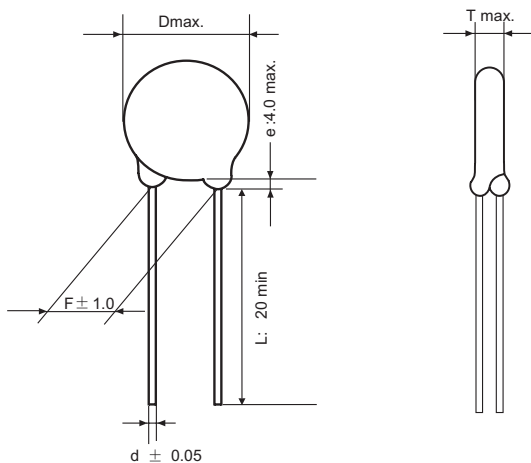

Lead code	A1	A2	A3	A4
F	2.5	5	7.5	10
L	20 min			
d	0.55			
e	4.0 Max.			

Unit: mm

3.5.2 : Straight short lead (Lead Style Code : B)

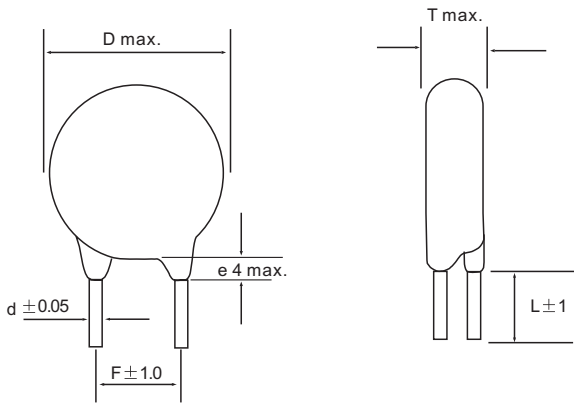

Lead code	B1	B2	B3	B4
F	2.5	5	7.5	10
L	5 or depend on client			
d	0.55			
e	4.0 Max.			

Unit: mm

3.5.3 : Inside Crimped Short lead (Lead Style Code : C)

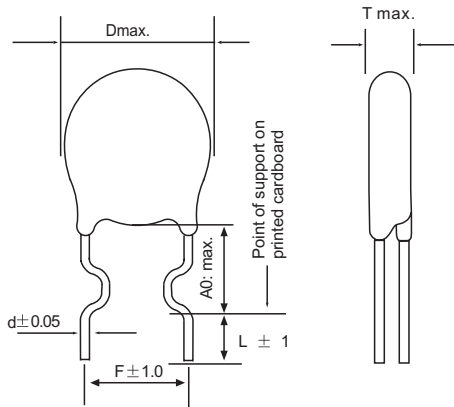

Lead code	C2	C3	C4
F	5	7.5	10
A0	5	5	6.5
L	5 or depend on client		
d	0.55		

Unit: mm

3.5.4 : Inside crimped long lead (Lead Style Code : D)

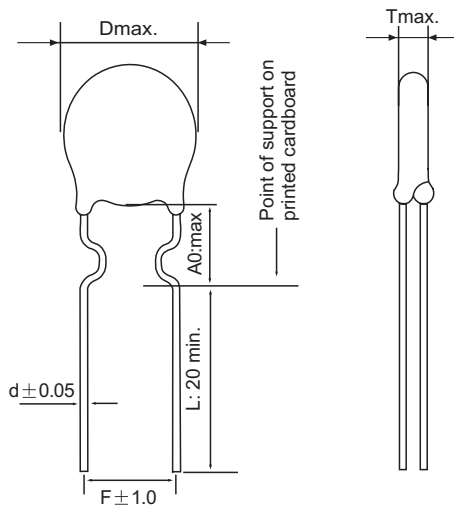

Lead code	D2	D3	D4
F	5	7.5	10
A0	5	5	6.5
L	20 mm		
d	0.55		

Unit: mm

3.5.5 : Outside crimped Short lead (Lead Style Code: E)

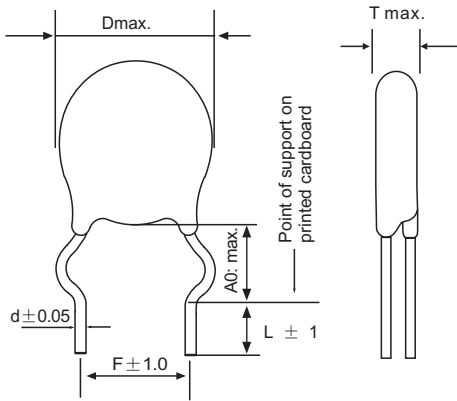

Lead code	E2	E3	E4
F	5	7.5	10
A	5	5	6.5
L	5 or depend on client		
d	0.55		

Unit: mm

3.5.6 : Outside crimped long lead (Lead Style Code: F)

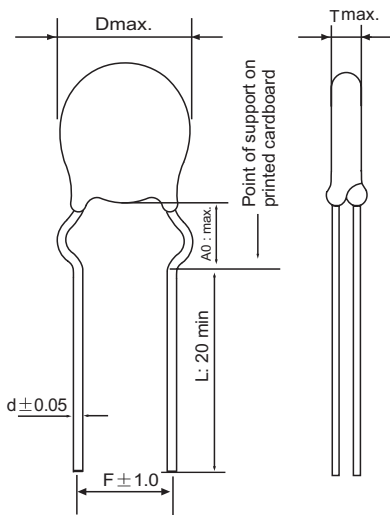

Lead code	F2	F3	F4
F	5	7.5	10
A0	5	5	6.5
L	20 min		
d	0.55		

Unit: mm

3.5.7 : Vertical crimped long lead (Lead Style Code: G)

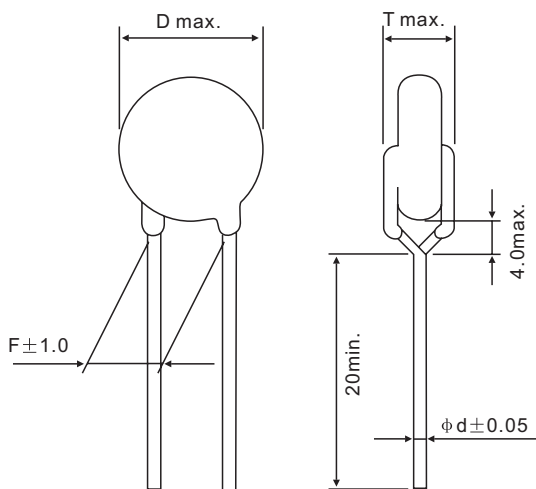

Lead code	G2	G3	G4
F	5	7.5	10
L	20 min		
d	0.55		

Unit: mm

3.5.8 : Vertical crimped short lead (Lead Style Code: H)

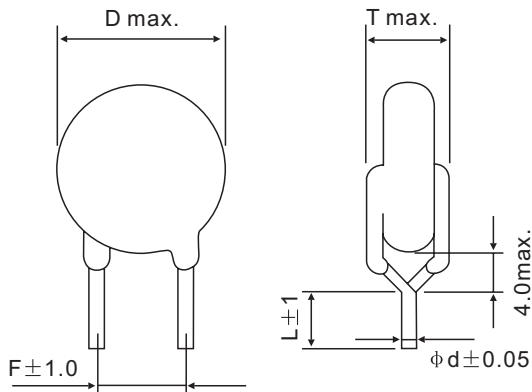

Lead code	H2	H3	H4
F	5	7.5	10
L	5 or depend on client		
d	0.55		

Unit: mm

3.5.9 : Double crimped snap lead, (Lead Style Code: M)

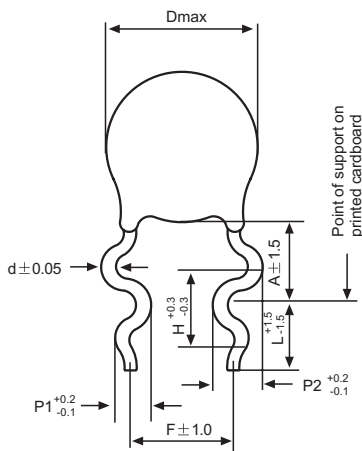

Lead code	M2	M3	M4
F	5	7.5	10
H	2.6	2.6	3.3
P1	1.25	1.25	1.65
P2	1.65	1.65	1.95
A	D < 8: 6.0 ± 1.5, D > 8: 7.0 ± 1.5		
L	3 to 30 mm		
d	0.55		

General Information: PCB max. thickness 1.6mm

Unit: mm

3.6 Lead Spacing Code

Code	Lead Spacing(mm)
2	5.0 ± 1.0
3	7.5 ± 1.0
4	10.0 ± 1.0

3.7 Packaging Code

Code	Pitch of components(mm)	Packaging
B	/	Bulk
A	12.7	Taping Ammo Pack
C	25.4	
D	15.0	
E	30.0	
R	12.7	Taping Reel Pack

3.8 Lead Length

Code	Lead Length (mm)
3.5	3.5
No figure	20.0min

3.9 Internal Code

Code	Meaning
W	Meeting RoHS
L	Halogen-Free & Meeting RoHS

4. MARKING

(1) Type Designation : HJ

(2) Nominal Capacitance : (Marked With 3 figures) ex: 222 = 2200pF

(3) Capacitance tolerance: K: $\pm 10\%$, M : $\pm 20\%$

(4) Subclass and rated voltage: X1:400V~ , Y1:250V~

(5) Manufacturer's trade mark: **WMEC**

(6) Manufacturing date and serial number: 21123

(7) Approved Monogram :

VDE-ENEC approval mark: 

CQC approval mark : 

CSA approval mark : 

UL approval mark : 

ENEC approval mark : 

KC approval mark : 

Marking ex.

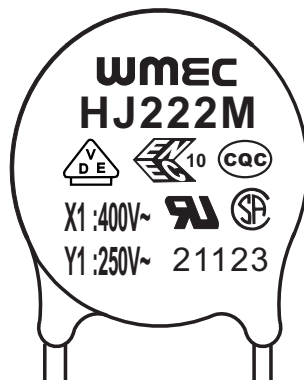

5. Rating and Characteristics

Rating and Characteristics

Type HJ (IEC60384-14 Sub-class X1,Y1) Rating and Characteristics

Part Number	Temp. Char	Capacitance (pF)	Doby Dia. D (mm)	Body Thicknes T (mm)	Lead Spacing F (mm)	Lead Dia. d (mm)	Lead Package Long Bulk)	Lead Package Short Bulk)	Lead Package Taping
HJS100○□□□	SL	10 ±5% or ±10%	9.0	8.0	10.0	0.55	G4B	H4B	G4C
HJS150○□□□	SL	15 ±5% or ±10%	9.0	8.0	10.0	0.55	G4B	H4B	G4C
HJS220○□□□	SL	22 ±5% or ±10%	9.0	8.0	10.0	0.55	G4B	H4B	G4C
HJS330○□□□	SL	33 ±5% or ±10%	9.0	8.0	10.0	0.55	G4B	H4B	G4C
HJS470○□□□	SL	47 ±5% or ±10%	9.0	8.0	10.0	0.55	G4B	H4B	G4C
HJS680○□□□	SL	68 ±5% or ±10%	9.0	8.0	10.0	0.55	G4B	H4B	G4C
HJB101K□□□	B/Y5P	100 +10,-10%	9.0	8.0	10.0	0.55	G4B	H4B	G4C
HJB121K□□□	B/Y5P	120 +10,-10%	9.0	8.0	10.0	0.55	G4B	H4B	G4C
HJB151K□□□	B/Y5P	150 +10,-10%	9.0	8.0	10.0	0.55	G4B	H4B	G4C
HJB181K□□□	B/Y5P	180 +10,-10%	9.0	8.0	10.0	0.55	G4B	H4B	G4C
HJB221K□□□	B/Y5P	220 +10,-10%	9.0	8.0	10.0	0.55	G4B	H4B	G4C
HJB271K□□□	B/Y5P	270 +10,-10%	9.0	8.0	10.0	0.55	G4B	H4B	G4C
HJB331K□□□	B/Y5P	330 +10,-10%	9.0	8.0	10.0	0.55	G4B	H4B	G4C
HJB391K□□□	B/Y5P	390 +10,-10%	9.0	8.0	10.0	0.55	G4B	H4B	G4C
HJB471K□□□	B/Y5P	470 +10,-10%	9.0	8.0	10.0	0.55	G4B	H4B	G4C
HJB561K□□□	B/Y5P	560 +10,-10%	10.0	8.0	10.0	0.55	G4B	H4B	G4C
HJB681K□□□	B/Y5P	680 +10,-10%	11.0	8.0	10.0	0.55	G4B	H4B	G4C
HJB821K□□□	B/Y5P	820 +10,-10%	11.0	8.0	10.0	0.55	G4B	H4B	G4C
HJB102K□□□	B/Y5P	1000 +10,-10%	12.0	8.0	10.0	0.55	G4B	H4B	G4C
HJE471M□□□	E/Y5U	470 +20,-20%	8.0	8.0	10.0	0.55	G4B	H4B	G4C
HJE561M□□□	E/Y5U	560 +20,-20%	8.0	8.0	10.0	0.55	G4B	H4B	G4C
HJE681M□□□	E/Y5U	680 +20,-20%	8.0	8.0	10.0	0.55	G4B	H4B	G4C
HJE102M□□□	E/Y5U	1000 +20,-20%	9.0	8.0	10.0	0.55	G4B	H4B	G4C
HJE122M□□□	E/Y5U	1200 +20,-20%	9.0	8.0	10.0	0.55	G4B	H4B	G4C
HJE152M□□□	E/Y5U	1500 +20,-20%	10.0	8.0	10.0	0.55	G4B	H4B	G4C
HJE182M□□□	E/Y5U	1800 +20,-20%	11.0	8.0	10.0	0.55	G4B	H4B	G4C
HJE222M□□□	E/Y5U	2200 +20,-20%	12.0	8.0	10.0	0.55	G4B	H4B	G4C
HJE272M□□□	E/Y5U	2700 +20,-20%	12.0	8.0	10.0	0.55	G4B	H4B	G4C
HJE332M□□□	E/Y5U	3300 +20,-20%	13.0	8.0	10.0	0.55	G4B	H4B	G4C
HJE392M□□□	E/Y5U	3900 +20,-20%	14.0	8.0	10.0	0.55	G4B	H4B	G4C
HJE472M□□□	E/Y5U	4700 +20,-20%	15.0	8.0	10.0	0.55	G4B	H4B	G4C

①Circle is filled with one to tolerance code of Capactance...J=±5%. K=±10%.

②Three blank columns are filled with the lead and packaging codes. Please refer to the three columns on the right for appropriate code.

6. Specification and test method

6.1 Operating temperature range:-25°C to 125°C

6.2 Test and measurement shall be made at the standard condition,(Temperature 15 to 35°C,relative humidity 45 to 75% and atmospheric pressure 86-106 kPa), unless otherwise specified herein
 If doubt occurred on the value of measurement, and measurement was requested by customer capacitors shall be measured at the reference condition(Temperature 20±2°C,relative humidity 60 to 70% and atmospheric pressure 86-106 kPa), unless otherwise specified herein

6.3 Performance

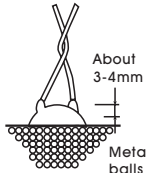
No.	Item		Specification	Testing Method																						
1	Appearance and Dimensions		No marked defect on appearance from and dimensions are within specified range.	The capacitor shall be inspected by naked eyes for Visible evidence of defect. Dimensions shall be measured with slide calipers.																						
2	Marking		To be easily legible.	The capacitor shall be inspected by naked eyes																						
3	Capacitance		Within specified tolerance.																							
4	Dissipation Factor(D.F.)		<table border="1"> <thead> <tr> <th>Char.</th> <th>Specification</th> </tr> </thead> <tbody> <tr> <td>B,E</td> <td>D.F≤2.5%</td> </tr> <tr> <td>SL</td> <td>Q≥400+20C (C<30PF) Q≥1000 (C≥30PF)</td> </tr> </tbody> </table>	Char.	Specification	B,E	D.F≤2.5%	SL	Q≥400+20C (C<30PF) Q≥1000 (C≥30PF)	The capacitance, dissipation factor shall be measured at 20±2°C with 1±0.1kHz.and AC1±0.1V(r.m.s).																
Char.	Specification																									
B,E	D.F≤2.5%																									
SL	Q≥400+20C (C<30PF) Q≥1000 (C≥30PF)																									
5	Insulation Resistance(I.R.)		10000M Ωmin.	The insulation resistance shall be measured with DC500±50V within 60±5 s of charging.																						
6	Dielectric Strength	Between Lead Wires	No failure.	The capacitor shall not be damage when AC4000V(r.m.s.) are applied between the lead wires for 60 s.																						
		Body Insulation	No failure.	First, the terminals of the capacitor shall be connected together. Then, as shown in Figure right, a metal foil shall be closely wrapped around the body of the capacitor to the distance of about 3 to 4 mm from each terminal.Then,the capacitor shall be insertedinto a container filled with metal balls of about 1 mm diameter. Finally, AC AC4000(r.m.s.) is applied for 60 s between the capacitor lead wires and metal balls. 																						
7	Temperature Characteristics		<table border="1"> <thead> <tr> <th>Char.</th> <th>Capacitance Change</th> </tr> </thead> <tbody> <tr> <td>B</td> <td>Within ±10%</td> </tr> <tr> <td>E</td> <td>Within $\pm\frac{20}{55}\%$</td> </tr> <tr> <td>SL</td> <td>+350~-1000ppm/°C</td> </tr> </tbody> </table> Temperature characteristic guarantee is -25 to +85°C	Char.	Capacitance Change	B	Within ±10%	E	Within $\pm\frac{20}{55}\%$	SL	+350~-1000ppm/°C	The capacitance measurement shall be made at each step specified in Table 3. <table border="1"> <thead> <tr> <th colspan="2"><Table.3></th> </tr> <tr> <th>Step</th> <th>Temperature(°C)</th> </tr> </thead> <tbody> <tr> <td>1</td> <td>+20±2</td> </tr> <tr> <td>2</td> <td>-25 ±2</td> </tr> <tr> <td>3</td> <td>+20±2</td> </tr> <tr> <td>4</td> <td>+85±2</td> </tr> <tr> <td>5</td> <td>+20±2</td> </tr> </tbody> </table>	<Table.3>		Step	Temperature(°C)	1	+20±2	2	-25 ±2	3	+20±2	4	+85±2	5	+20±2
Char.	Capacitance Change																									
B	Within ±10%																									
E	Within $\pm\frac{20}{55}\%$																									
SL	+350~-1000ppm/°C																									
<Table.3>																										
Step	Temperature(°C)																									
1	+20±2																									
2	-25 ±2																									
3	+20±2																									
4	+85±2																									
5	+20±2																									
8	Solderability of Leads		Lead wire shall be soldered with uniformly coated on the axial direction over 3/ 4p of the circumferential direction.	The lead wire of a capacitor shall be dipped into molten solder of 235±5°C for 2±0.5 s. The depth of immersion is up to about 1.5 to 2.0mm from the root of lead wires.																						

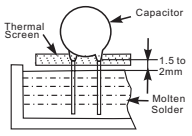
No.	Item	Specification	Testing Method	
9	Soldering Effect	Appearance	No marked defect.	
		Capacitance Change	Within $\pm 10\%$	
		I.R.	1000M Ω min.	
		Dielectric Strength	Pre Item 6.	
			<p>As in figure, the lead wires should be immersed solder of $350 \pm 10^\circ\text{C}$ or $260 \pm 5^\circ\text{C}$ up to 1.5 to 2.0mm from the root of terminal for 3.5 ± 0.5 s (10 ± 1 s for $260 \pm 5^\circ\text{C}$).</p> <p>Pre-treatment: Capacitor should be stored at $85 \pm 2^\circ\text{C}$ for 1 h, then placed at *room condition for 24 ± 2 h before initial measurements.</p> <p>Post-treatment: Capacitor should be stored for 1 to 2 h at *room condition.</p> 	
10	Vibration Resistance	Appearance	No marked defect.	
		Capacitance	Within the specified tolerance.	
		D.F. Q	Char.	Specification
			B,E	D.F. $\leq 2.5\%$
SL	$Q \geq 400 + 20C^{*1}$ ($C < 30\text{pF}$) $Q \geq 1000$ ($C \geq 30\text{pF}$)			
			<p>The capacitor should firmly be soldered to the supporting lead wire and vibrated at a frequency range of 10 to 55Hz, 1.5mm in total amplitude, with about a 1 minute rate of vibration change from 10Hz to 55Hz and back to 10Hz.</p> <p>Apply for total of 6 hrs., 2 hrs each in 3 mutually perpendicular directions.</p>	
11	Humidity (Under Steady State)	Appearance	No marked defect.	
		Capacitance Change	Char.	Capacitance Change
			B	Within $\pm 10\%$
			E	Within $\pm 15\%$
			SL	Within $\pm 5\%$
		D.F. Q	Char.	Specification
B,E	D.F. $\leq 5.0\%$			
SL	$Q \geq 275 + 5/2C^{*1}$ ($C < 30\text{pF}$) $Q \geq 350$ ($C \geq 30\text{pF}$)			
I.R.	3000M Ω min.			
Dielectric Strength	Per Item 6.			
			<p>Set the capacitor for 500 ± 12 h at $40 \pm 2^\circ\text{C}$ in 90 to 95% relative humidity.</p> <p>Post-treatment: Capacitor should be stored for 1 to 2 h at *2room condition.</p>	
12	Humidity Loading	Appearance	No marked defect.	
		Capacitance Change	Char.	Capacitance Change
			B	Within $\pm 10\%$
			E	Within $\pm 15\%$
			SL	Within $\pm 5\%$
		D.F. Q	Char.	Specification
B,E	D.F. $\leq 5.0\%$			
SL	$Q \geq 275 + 5/2C^{*1}$ ($C < 30\text{pF}$) $Q \geq 350$ ($C \geq 30\text{pF}$)			
I.R.	3000M Ω min.			
Dielectric Strength	Per Item 6.			
			<p>Apply the rated voltage for 500 ± 12 h at $40 \pm 2^\circ\text{C}$, in 90 to 95% relative humidity.</p> <p>Post-treatment: Capacitor should be stored for 1 to 2 h at *2room condition.</p>	

*1 "C" expresses nominal capacitance value(pF).

*2 "Room condition" Temperature; 15 to 35°C , Relative humidity; 45 to 75%, Atmospheric pressure: 86 to 106kPa

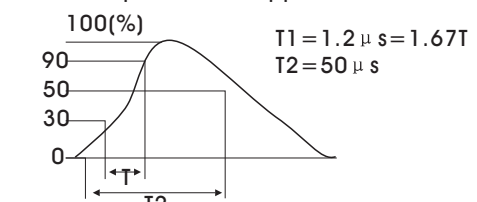
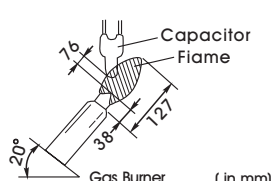
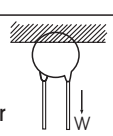
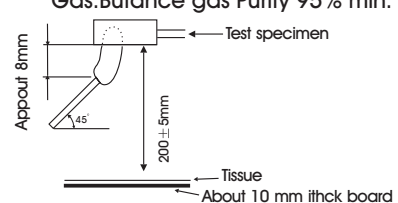
No.	Item	Specification	Testing Method			
13	Appearance	No marked defect.	Impulse Voltage Each individual capacitor shall be subjected to a 8kV impulses for three times. The time between impulses should be not less than 10S. After the capacitors are applied to life test.  T1 = 1.2 μs = 1.67T T2 = 50 μs Apply a voltage of table 4 for 1000 h at 105+2/0°C, and relative humidity of 50% max... <Table.4> <hr/> Applied voltage <hr/> AC425V(r.m.s.), Except that once each hour the voltage is increased to AC1000V(r.m.s.)for 0.1s.			
	Capacitance Change	Within ± 20%				
	I.R.	3000MΩ min.				
	Dielectric Strength	Per Item 6.				
	Discharge Test(II)	Per Item 9.				
14	Flame Test	The capacitor flame discontinue as follows.	Post-treatment: Capacitor shall be stored for 1 to 2 h at *room condition. The capacitor shall be subjected to applied flame for 15 s and then removed for 15 s until 5 cycles. 			
		<table border="1"> <thead> <tr> <th>Cycle</th> <th>Time</th> </tr> </thead> <tbody> <tr> <td>1 to 4</td> <td>30 s max.</td> </tr> <tr> <td>5</td> <td>60 s max.</td> </tr> </tbody> </table>		Cycle	Time	1 to 4
Cycle	Time					
1 to 4	30 s max.					
5	60 s max.					
15	Robustness of terminations	Tensile	As a figure,fix the body of capacitor, apply a tensile weight gradually to each lead wire in the radial direction of capacitor up to 10N and keep it for 10±1 s.  Each lead wire shall be subjected to 5N weight and then a 90° bend, at the point of egress,in one direction, return to original position,and then a 90° bend in the opposite direction at the rate of one bend in 2 to 3 s.			
		Bending				
16	Passive Flammability	The burning time shall not be exceeded the time 30 s. The tissue paper shall not ignite.	The capacitor under test shall be held in the flame in the position which best promotes burning. Each specimen shall only be exposed once to the flame. Time of exposure to flame: 30 s. Length of flame: 12±1mm Gas burner: Length 35mm min. Inside Dia.: 0.5±0.1mm Outside Dia.: 0.9mm max. Gas:Butane gas Purity 95% min. 			

*1 “C ” expresses nominal capacitance value(pF).

* “Room condition ” Temperature; 15 to 35°C, Relative humidity; 45 to 75%, Atmospheric pressure: 86 to 106kPa

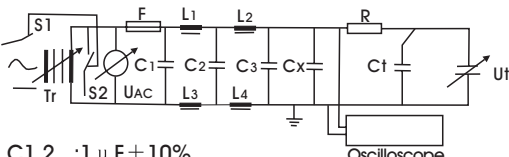
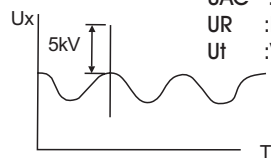
No.	Item	Specification	Testing Method																																																												
17	Active Flammability	The cheese-cloth shall not be on fire.	<p>The capacitor shall be individually wrapped in at least one but not more than two complete layers of cheese-cloth. The capacitor shall be subjected to 20 discharges. The interval between successive discharges shall be 5 s. The UAC shall be maintained for 2 min after the last discharge.</p>  <p> C1,2 : $1 \mu F \pm 10\%$ C3 : $0.033 \mu F \pm 5\%$ 10kV Ct : $3 \mu F \pm 5\%$ 10kV Cx : Capacitor under test F : Fuse, Rated 10A L1 to 4 : $1.5mH \pm 20\%$: 16A Rod core choke R : $100 \Omega \pm 2\%$ UAC : $UR \pm 5\%$ UR : Rated voltage Ut : Voltage applied to Ct </p> 																																																												
18	Temperature and Immersion Cycle	<table border="1" data-bbox="359 1008 912 1776"> <tr> <td colspan="2">Appearance</td> <td colspan="2">No marked defect.</td> </tr> <tr> <td rowspan="3">Capacitance Change</td> <td>Char.</td> <td colspan="2">Capacitance Change</td> </tr> <tr> <td>B</td> <td colspan="2">Within $\pm 10\%$</td> </tr> <tr> <td>E</td> <td colspan="2">Within $\pm 15\%$</td> </tr> <tr> <td>SL</td> <td colspan="2">Within $\pm 5\%$</td> </tr> <tr> <td rowspan="3">D.F.</td> <td>Char.</td> <td colspan="2">Specification</td> </tr> <tr> <td>B, E</td> <td colspan="2">$D.F. \leq 5.0\%$</td> </tr> <tr> <td>SL</td> <td colspan="2"> $Q \geq 275 + 2.5C$ ($C < 30PF$) $Q \geq 350$ ($C \geq 30PF$) </td> </tr> <tr> <td>I.R.</td> <td colspan="2">3000M Ω min.</td> </tr> <tr> <td>Dielectric Strength</td> <td colspan="2">Per Item 6.</td> </tr> </table>	Appearance		No marked defect.		Capacitance Change	Char.	Capacitance Change		B	Within $\pm 10\%$		E	Within $\pm 15\%$		SL	Within $\pm 5\%$		D.F.	Char.	Specification		B, E	$D.F. \leq 5.0\%$		SL	$Q \geq 275 + 2.5C$ ($C < 30PF$) $Q \geq 350$ ($C \geq 30PF$)		I.R.	3000M Ω min.		Dielectric Strength	Per Item 6.		<p>The capacitor shall be subjected to 5 temperature cycles, then consecutively to 2 immersion cycles.</p> <p>< Temperature cycle ></p> <table border="1" data-bbox="925 1120 1404 1254"> <thead> <tr> <th>Step</th> <th>Temperature($^{\circ}C$)</th> <th>Time</th> </tr> </thead> <tbody> <tr> <td>1</td> <td>-25 + 0/-3</td> <td>30 min</td> </tr> <tr> <td>2</td> <td>Room temp.</td> <td>3 min</td> </tr> <tr> <td>3</td> <td>+125 + 3/-0</td> <td>30 min</td> </tr> <tr> <td>4</td> <td>Room temp.</td> <td>3 min</td> </tr> </tbody> </table> <p>Cycle time: 5 cycle</p> <p>< Immersion cycle ></p> <table border="1" data-bbox="925 1344 1404 1512"> <thead> <tr> <th>Step</th> <th>Temperature($^{\circ}C$)</th> <th>Time</th> <th>Immersion water</th> </tr> </thead> <tbody> <tr> <td>1</td> <td>+65 + 5/-0</td> <td>15 min</td> <td>Clean water</td> </tr> <tr> <td>2</td> <td>Room temp.</td> <td>15 min</td> <td>Salt water</td> </tr> </tbody> </table> <p>Pre-treatment: Capacitor shall be stored at $85 \pm 2^{\circ}C$ for 1 h, then placed at *room condition for 24 ± 2 h.</p> <p>Post-treatment: Capacitor shall be stored for 24 ± 2 h at *room condition.</p>	Step	Temperature($^{\circ}C$)	Time	1	-25 + 0/-3	30 min	2	Room temp.	3 min	3	+125 + 3/-0	30 min	4	Room temp.	3 min	Step	Temperature($^{\circ}C$)	Time	Immersion water	1	+65 + 5/-0	15 min	Clean water	2	Room temp.	15 min	Salt water
Appearance		No marked defect.																																																													
Capacitance Change	Char.	Capacitance Change																																																													
	B	Within $\pm 10\%$																																																													
	E	Within $\pm 15\%$																																																													
SL	Within $\pm 5\%$																																																														
D.F.	Char.	Specification																																																													
	B, E	$D.F. \leq 5.0\%$																																																													
	SL	$Q \geq 275 + 2.5C$ ($C < 30PF$) $Q \geq 350$ ($C \geq 30PF$)																																																													
I.R.	3000M Ω min.																																																														
Dielectric Strength	Per Item 6.																																																														
Step	Temperature($^{\circ}C$)	Time																																																													
1	-25 + 0/-3	30 min																																																													
2	Room temp.	3 min																																																													
3	+125 + 3/-0	30 min																																																													
4	Room temp.	3 min																																																													
Step	Temperature($^{\circ}C$)	Time	Immersion water																																																												
1	+65 + 5/-0	15 min	Clean water																																																												
2	Room temp.	15 min	Salt water																																																												

*1 "C" expresses nominal capacitance value(pF).

* "Room condition" Temperature; 15 to 35 $^{\circ}C$, Relative humidity; 45 to 75%, Atmospheric pressure: 86 to 106kPa

7. Characteristics Data (Typical Example)

7.1 Capacitance-Temperature Characteristics

Char: B(Y5P)

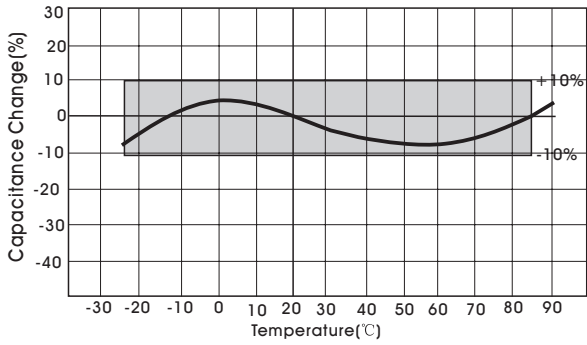

Char:E (Y5U)

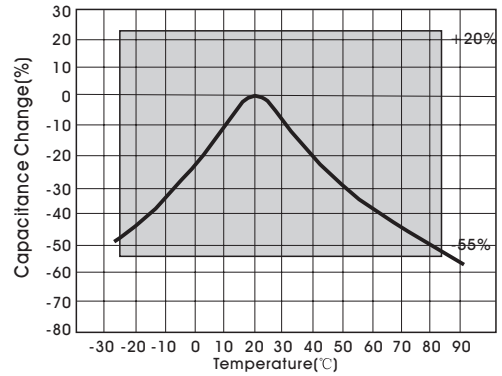

7.2 Impedance vs. Frequency Characteristics

Type HJ

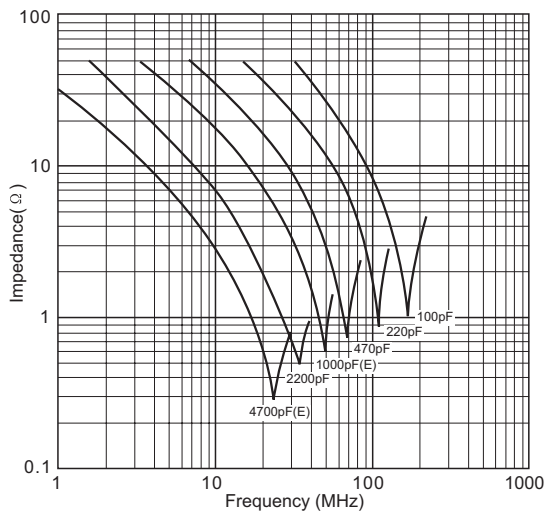

7.3 Leakage Current Characteristics

Type HJ (B char.)

AC voltage : 60Hz
Temperature : 25°C

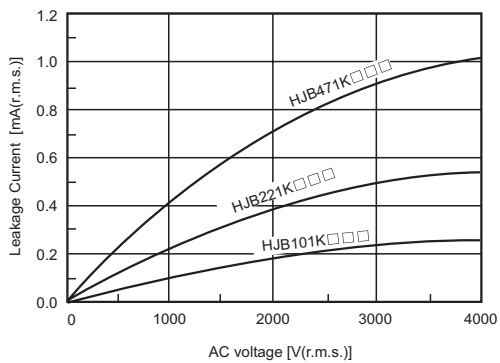

Type HJ (E char.)

AC voltage : 60Hz
Temperature : 25°C

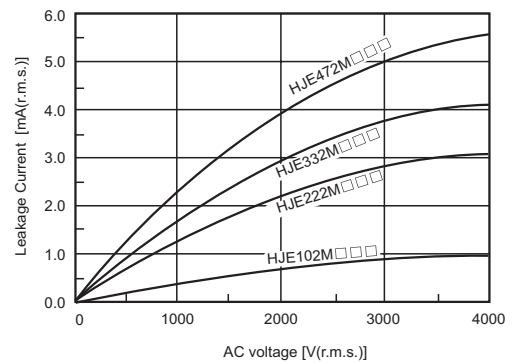

8.1 TAPING SPECIFICATION

- 12.7mm pitch/ lead spacing 5.0/7.5 mm taping (Lead Code:A2,A3,D2,D3,F2,F3,G2,G3)

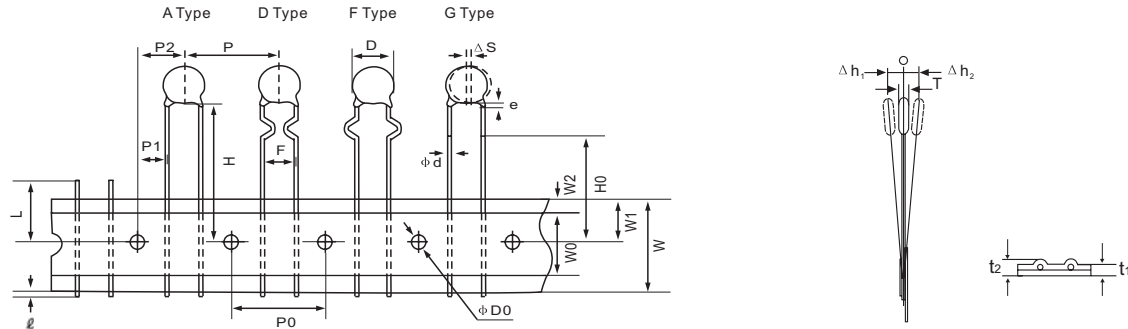

- 25.4mm pitch/ lead spacing 7.5/10.0mm taping (Lead Code:A3,A4,D3,D4,F3,F4,G3,G4)

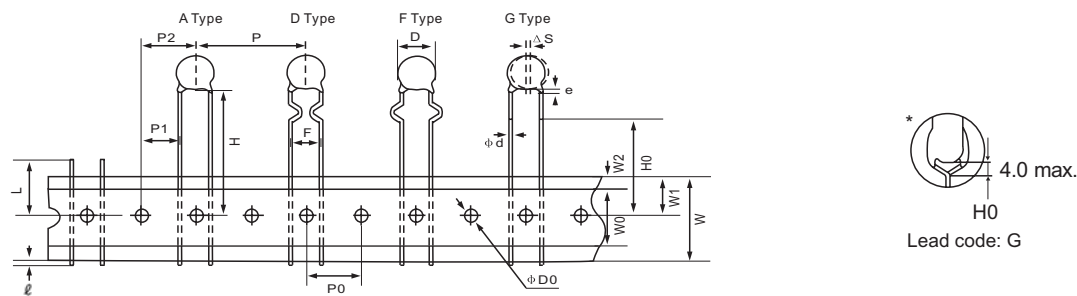

Item	Code	A2/D2/F2/G2	A3/D3/F3/G3	A3/D3/F3/G3	A4/D4/F4/G4
Pitch of component	P	12.7	12.7	25.4	25.4
Pitch of sprocket hole	P ₀	12.7±0.3	12.7±0.3	12.7±0.3	12.7±0.3
Lead spacing	F	5.0±1.0	7.5±1.0	7.5±1.0	10.0±1.0
Length from hole center to component center	P ₂	6.35±1.3	6.35±1.3	12.7±1.3	12.7±1.3
Length from hole center to lead	P ₁	3.85±0.7	2.6±0.7	8.95±1.0	7.7±1.0
Body diameter	D	See the individual product specification			
Deviation along tape, left or right	ΔS	0±2.0			
Carrier tape width	W	18.0±0.5			
Position of sprocket hole	W ₁	9.0±0.5			
Lead distance between reference and bottom planes	H	20.0±1.5 (Lead Code:A2/A3/A4)			
	H ₀	18.0 ^{+1.5} _{-0.5} (Crimp type)			
Diameter of sprocket hole	φD ₀	4.0±0.2			
Lead diameter	φd	0.55±0.05			
Total tape thickness	t ₁	0.6±0.3			
Total thickness, tape and lead wire	t ₂	2.0 max.			
Body thickness	T	See the individual product specification			
Portion to cut in case of defect	L	11.0 max.			
Hold down tape width	W ₀	10.0±2			
Hold down tape position	W ₂	1.5±1.5			
Coating extension on lead	e	3.0 max. (Crimp type:Up to the end of crimp)			
Deviation across tape	$\frac{\Delta h_1}{\Delta h_2}$	2.0 max.			
Protrusion length	ℓ	+0.5 to -1.0			

(in mm)

8.2 TAPING SPECIFICATION

- 15.0mm pitch/ lead spacing 5.0/7.5 mm taping (Lead Code:A2,A3,D2,D3,F2,F3,G2,G3)

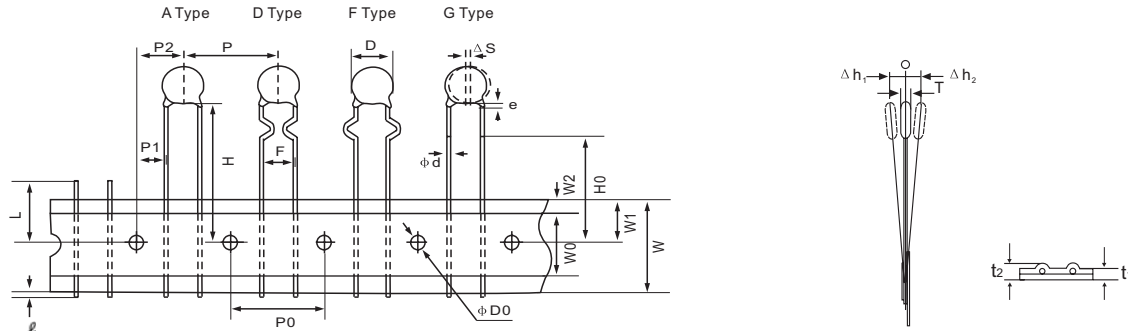

- 30.0mm pitch/ lead spacing 7.5/10.0mm taping (Lead Code:A3,A4,D3,D4,F3,F4,G3,G4)

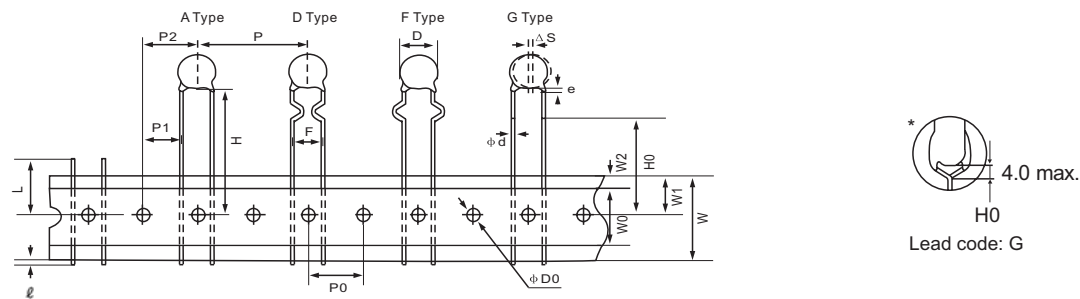

Item	Code	A2/D2/F2/G2	A3/D3/F3/G3	A3/D3/F3/G3	A4/D4/F4/G4
Pitch of component	P	15.0	15.0	30.0	30.0
Pitch of sprocket hole	P ₀	15.0±0.3	15.0±0.3	15.0±0.3	15.0±0.3
Lead spacing	F	5.0±1.0	7.5±1.0	7.5±1.0	10.0±1.0
Length from hole center to component center	P ₂	7.5±1.3	7.5±1.3	15.0±1.3	15.0±1.3
Length from hole center to lead	P ₁	5.0±0.7	3.75±0.7	11.25±1.0	10.0±1.0
Body diameter	D	See the individual product specification			
Deviation along tape, left or right	ΔS	0±2.0			
Carrier tape width	W	18.0±0.5			
Position of sprocket hole	W ₁	9.0±0.5			
Lead distance between reference and bottom planes	H	20.0±1.5 (Lead Code:A2/A3/A4)			
	H ₀	18.0 ^{+1.5} _{-0.5} (Crimp type)			
Diameter of sprocket hole	φD ₀	4.0±0.2			
Lead diameter	φd	0.55±0.05			
Total tape thickness	t ₁	0.6±0.3			
Total thickness, tape and lead wire	t ₂	2.0 max.			
Body thickness	T	See the individual product specification			
Portion to cut in case of defect	L	11.0 max.			
Hold down tape width	W ₀	10.0±2			
Hold down tape position	W ₂	1.5±1.5			
Coating extension on lead	e	3.0 max. (Crimp type:Up to the end of crimp)			
Deviation across tape	Δh ₁	2.0 max.			
	Δh ₂				
Protrusion length	ℓ	+0.5 to -1.0			

(in mm)

9 PACKAGING STYLES

9.1 Taping: Reel Packaging

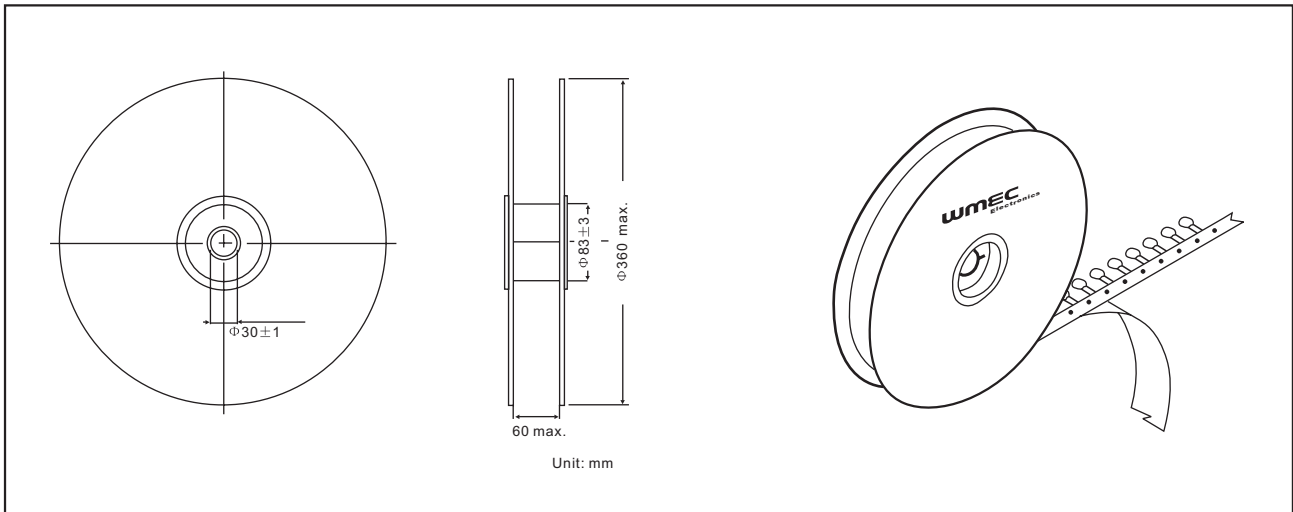

9.2 Taping: Ammo Packaging

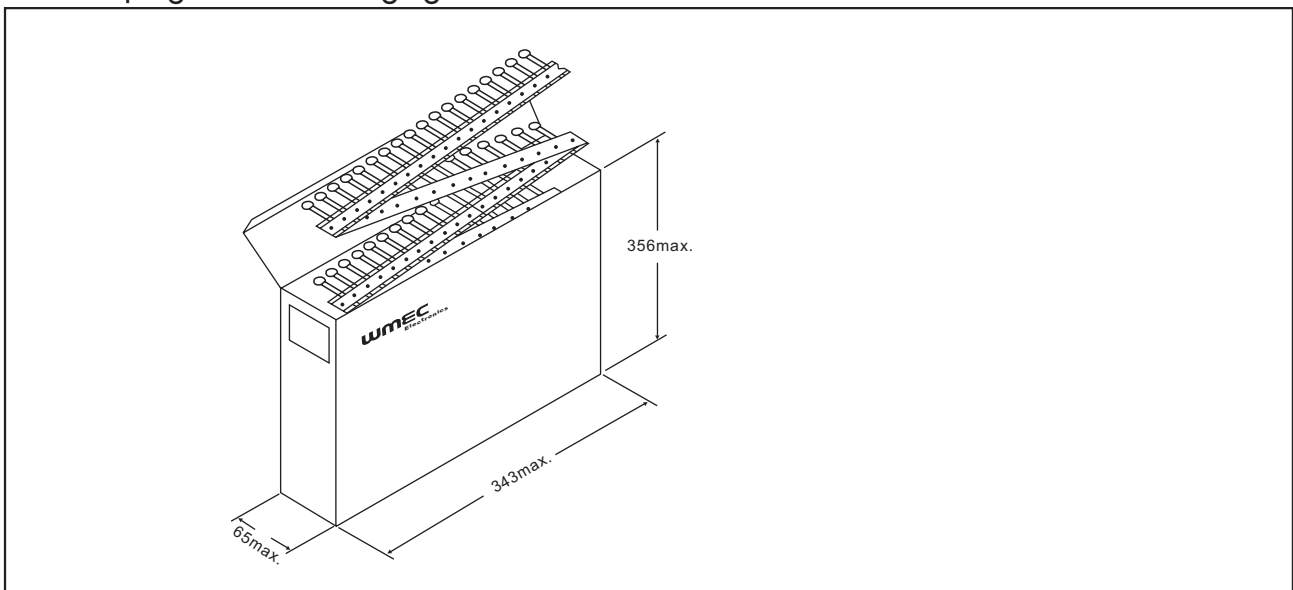

9.3 Bulk

Polyethylene Bag

10 : Packaging Quantity:

(Bulk) 500 pcs

11 : Label and Transport

Capacitors shall be packaged prior to shipment so as to prevent damage during transportation and storage.

Shipping carton contains the following information on the label

Ex.

- a) Our Part No.
- b) Quantity
- c) Lot No.
- D) Manufacturer's Name.



12 : Notification before the modification

We,ll previously notify the modified place of manufacture, Manufactured articles and materials.

The operating conditions for the guarantee of this product are as shown in the specification.

Please note the Wanming Electronics co.,Ltd. Shall not be responsible for a failure and/or abnormality which are caused by use under the conditions other than the aforesaid operating conditions.